



TOTEM



Artikelnummern:
 19" Silber/Grau/Gelb - 232004
 19" Blau/Weiss - 232020
 21" Silber/Grau/Gelb - 232005
 21" Blau/Weiss - 232021

Modell	Maurice	Bremsen	Shimano MT-200
Rahmen	19" / 48.3cm - 21" / 53.3cm	Schaltung	Shimano SL-M2010
Farbe	Silber/Grau/Gelb oder Blau/Weiss	Umwerfer	Shimano RD-M370
Motor	VINKA E20 Center Motor	Kassette	Shimano CS-HG200-9
Akku	36V - 14Ah / 504Wh - Samsung Zellen	Radsatz	Stars J19SF
Ladezeit	~ 7 Stunden für 100%	Reifen	CST 29*2.1
Reichweite*	Bis zu 120 km	Sattel	Vader
Display	VINKA DS20 LCD Display	Sattelstütze	Mode 30.9mm*300mm
Gabel	Suntour XCM-DS-RLO-29 - 100	Gewicht	23kg - 23.2kg

*Die Lebensdauer einer Batterie hängt von verschiedenen Faktoren ab wie z.B. das Gewicht des Fahrers, den Wetterbedingungen, der Hangneigung, der Abnutzung und Druck der Reifen usw.

Geometrie Tabelle

Größen:

M

L

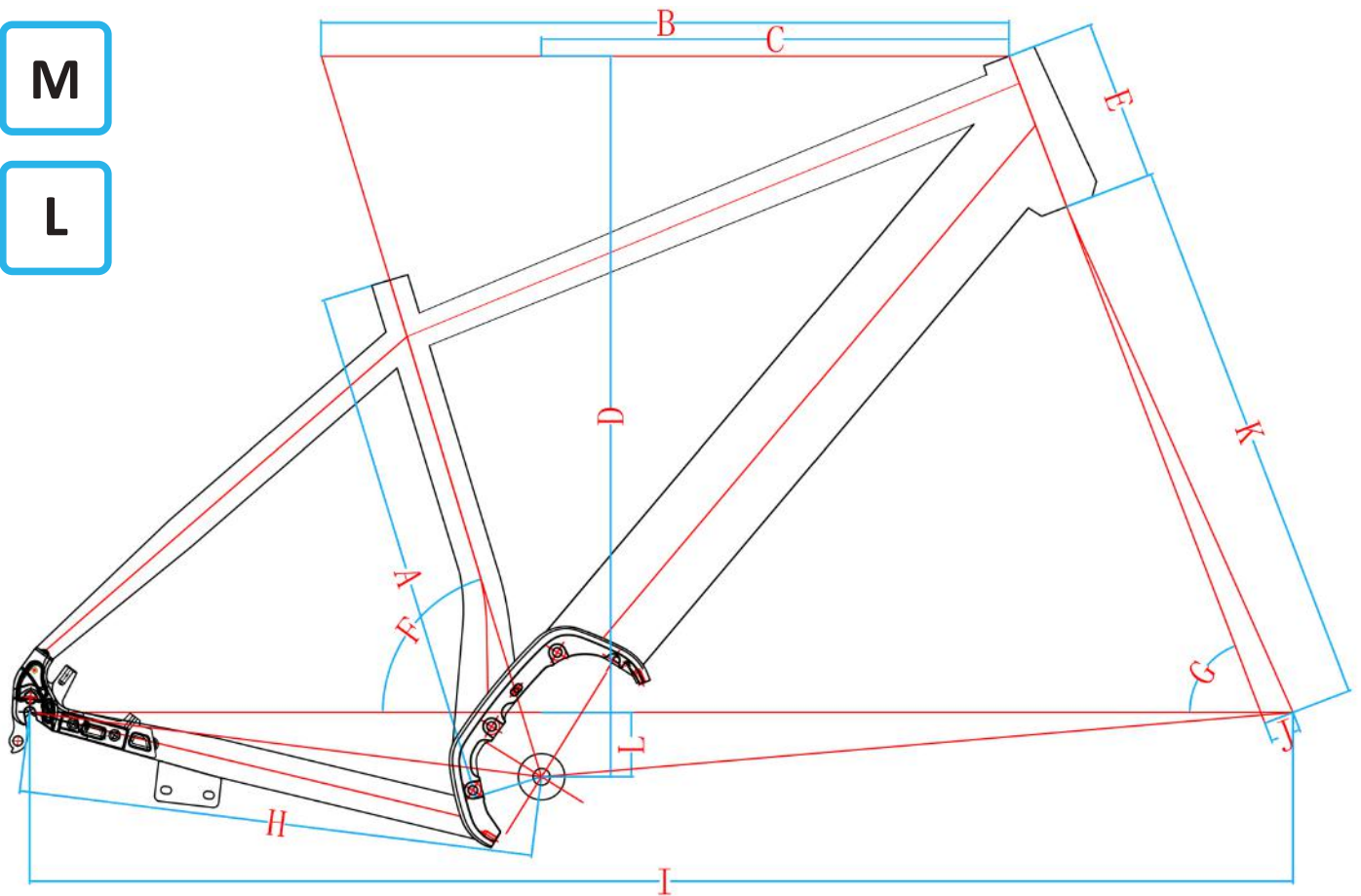

	A	B	C	D	E	F	G	H	I	J	K	L
M	483	640	434.8	670.1	150	73°	69°	480	1175.2	28	514.2	60
L	533	640	434.8	670.1	150	73°	69°	480	1175.2	28	514.2	60



TOTEM